

Figure 5.6
Buildup of DNP3 message

↑
Link Layer

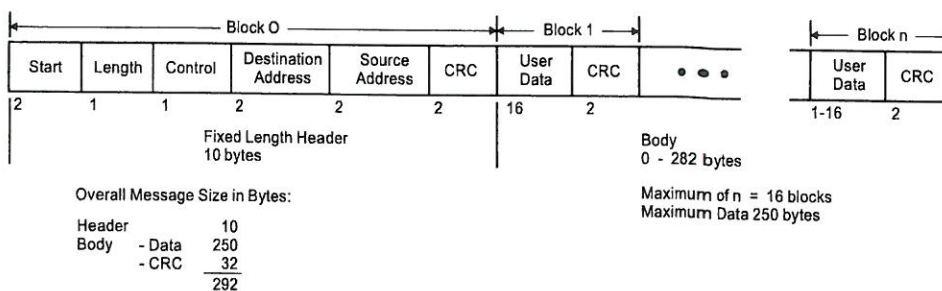

Figure 5.9
FT3 frame format

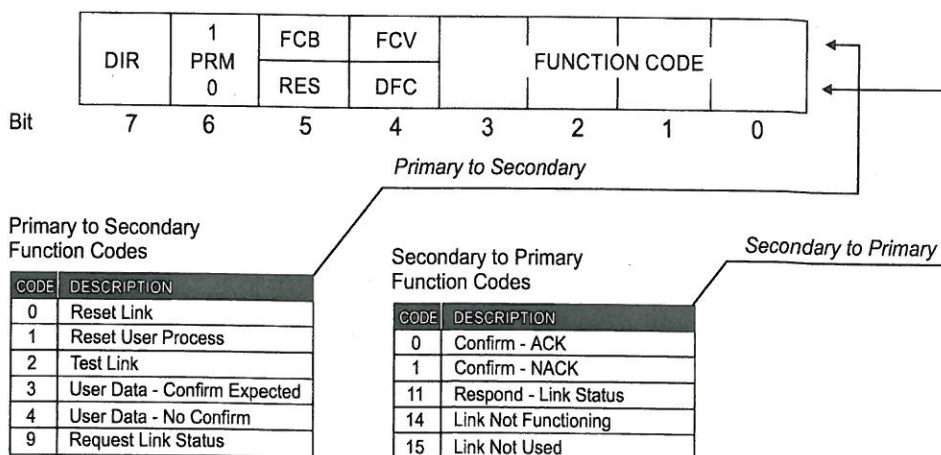

Figure 5.10
Control byte

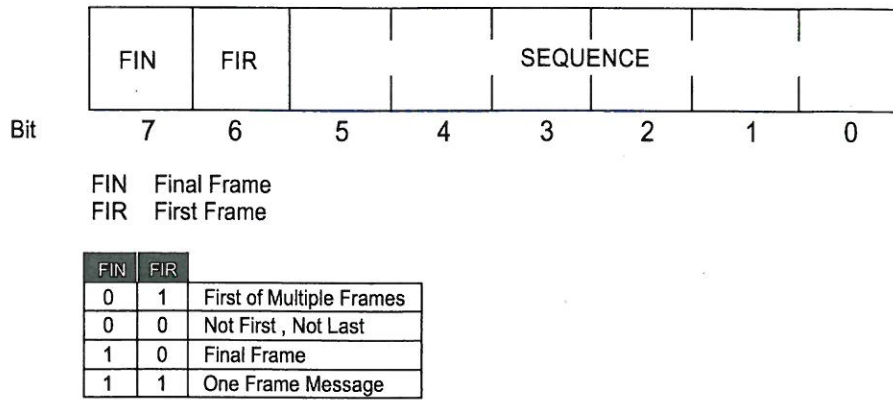

Figure 5.20
Transport header byte

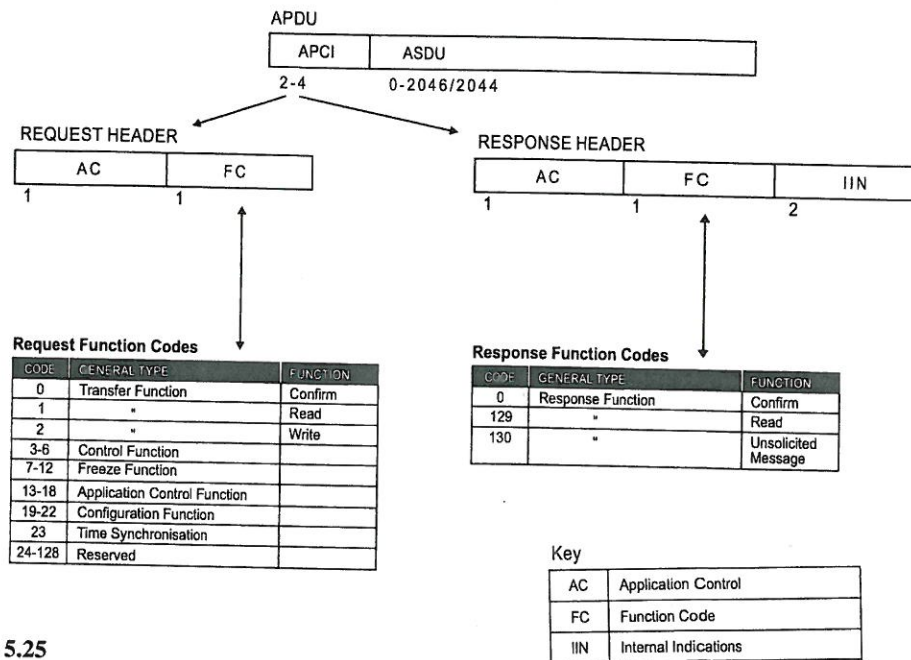

Figure 5.25
Application function codes

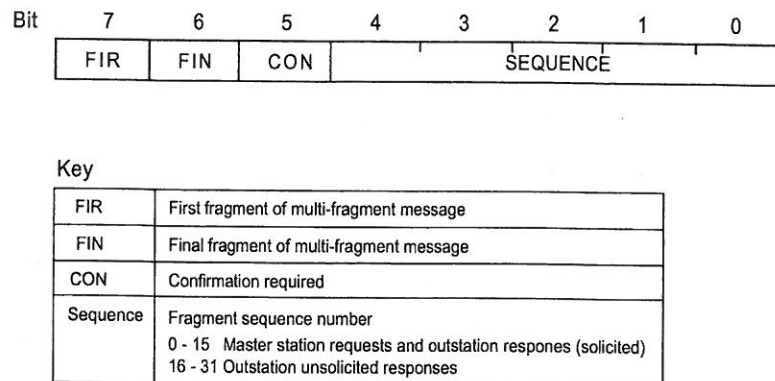

Figure 5.24
Application control field